

Great Lakes Classic

Showmanship - Rookie and Level 1

Show Date: 9/15/22

w w w . H o r s e S h o w P a t t e r n s . c o m

w w w . H o r s e S h o w P a t t e r n s . c o m

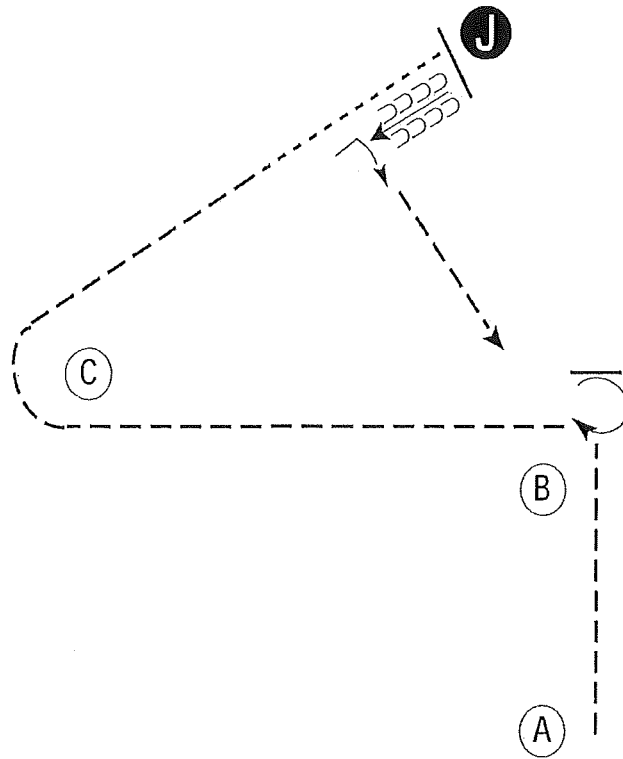

Be ready at A.

1. Trot from A past B.
2. Stop and perform 270 degree turn.
3. Trot around C. Break to a walk half way to the Judge.
4. Walk to Judge, stop and set up for inspection.
5. When dismissed back one horse length.
6. Perform a 90 degree turn and trot to the line-up or follow the instructions of your ring steward.

Walk -----
Trot - - - - -
Back ← 
Marker (B)
Judge (J)

[S/3-14]

Pattern Provided by:

Great Lakes Classic

Showmanship - Amateur, Select, Youth

Show Date: 9/15/22

w w w . H o r s e S h o w P a t t e r n s . c o m

w w w . H o r s e S h o w P a t t e r n s . c o m

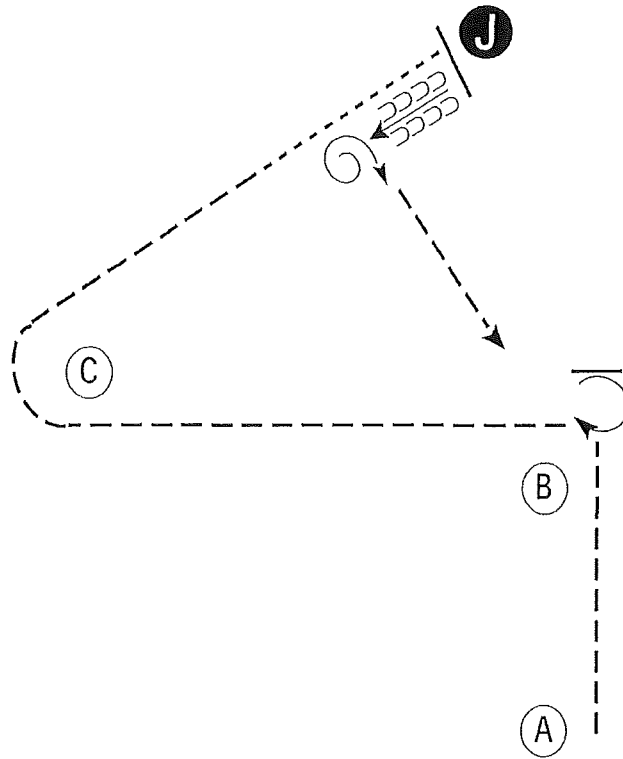

Be ready at A.

1. Trot from A past B.
2. Stop and perform 270 degree turn.
3. Trot around C. Break to a walk half way to the Judge.
4. Walk to Judge, stop and set up for inspection.
5. When dismissed back one horse length.
6. Perform a 450 degree turn and trot to the line-up or follow the instructions of your ring steward.

- Walk -----
- Trot - - - - -
- Back ← - - - - -
- Marker (B)
- Judge (J)

[S/3-14]

Pattern Provided by:

Great Lakes Classic

Hunt Seat Equitation - Rookie & Level 1

Show Date: 9/15/22

www.HorseShowPatterns.com

www.HorseShowPatterns.com

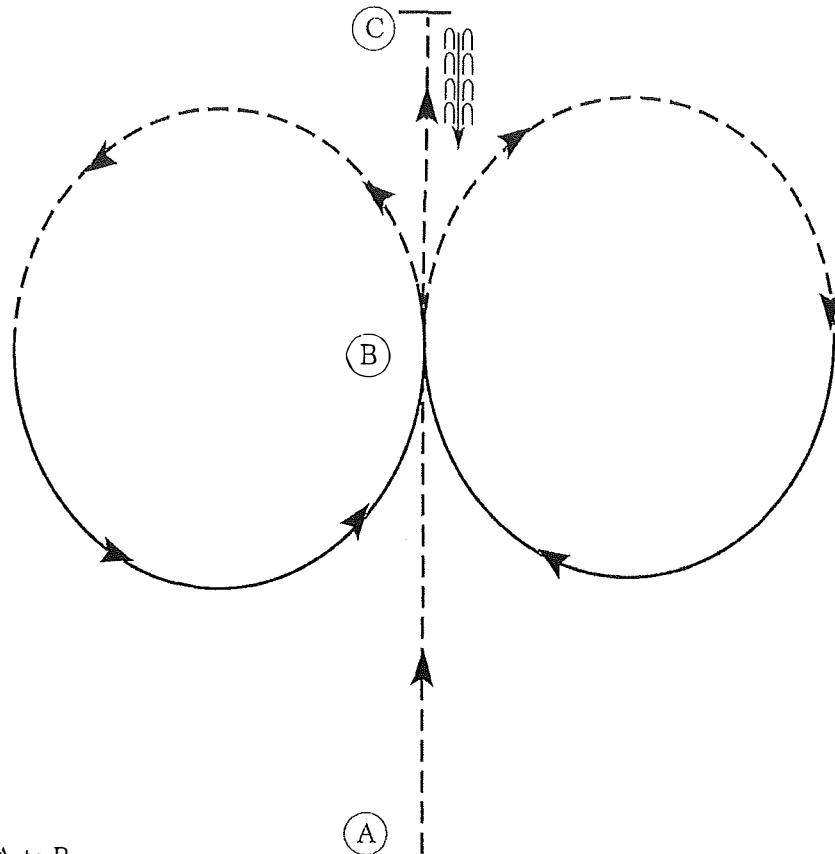

1. Sitting trot A to B
2. At B posting trot on the left diagonal in a half circle.
3. Canter on the right lead back to B.
4. Posting trot on the right diagonal in a half circle.
5. Canter on the left lead back to B.
6. Sitting trot to C.
7. Stop at C and back approximately one horse length.

Exit at a sitting trot.

Walk
Trot	-----
Extended Trot	—————
Canter	—————
Leg Yield	
Lead Change	///
Back	←○○○○
Marker	ⓑ
Sidepass	←-----→
Hand Gallop	—————

[HSE/2-21]

Pattern Provided by:

Great Lakes Classic

Hunt Seat Equitation - Amateur, Select, Youth

Show Date: 9/15/22

www.HorseShowPatterns.com

www.HorseShowPatterns.com

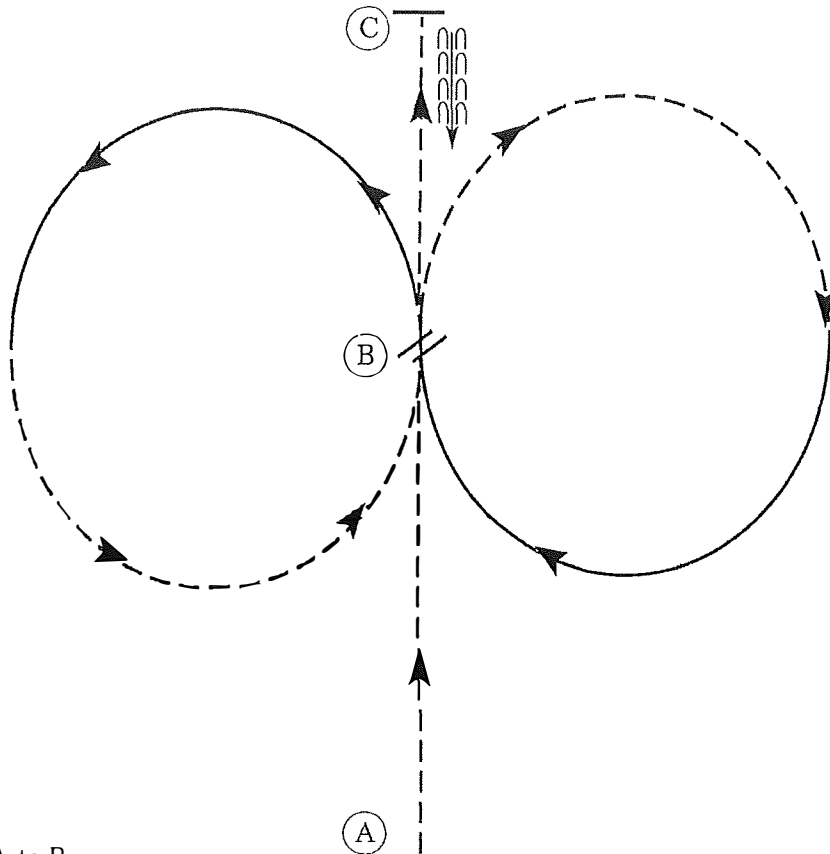

1. Sitting trot A to B
2. At B posting trot on the left diagonal in a half circle.
3. Canter on the right lead back to B.
4. Change leads at B and canter on the left lead in a half circle.
5. Posting trot on the right diagonal back to B.
6. Sitting trot to C.
7. Stop at C and back approximately one horse length.

Exit at a sitting trot.

Walk	-----
Trot	- - - - -
Extended Trot	— — — — —
Canter	—————
Leg Yield	
Lead Change	— / —
Back	←←←←←
Marker	⊙
Sidepass	← - - - - →
Hand Gallop	— — — — —

[HSE/3-21]

Pattern Provided by:

Great Lakes Classic
Horsemanship - All Divisions
except Small Fry
9-16-22

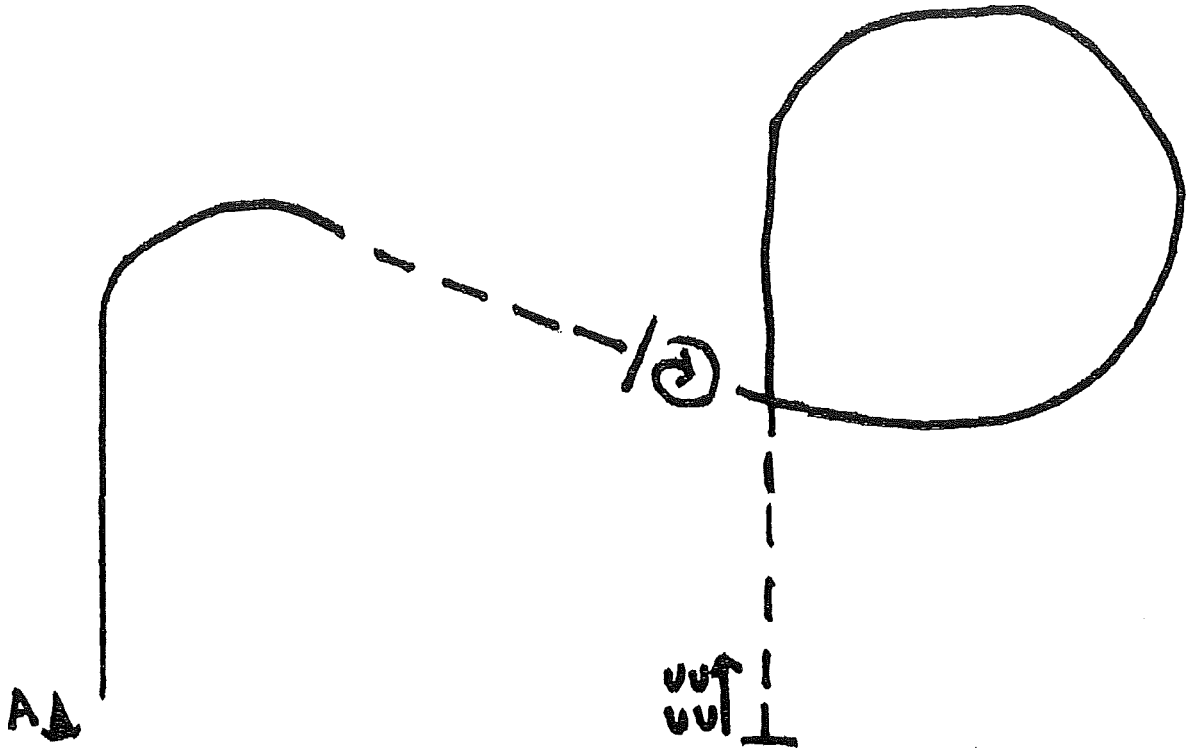

1. Begin at A
2. Lope right lead as shown
3. Break to extended trot to center and stop.
4. Perform a 360 degree turn to the right.
5. Lope left lead as shown
6. Break to a jog
7. Stop even with A and back 1 horse length. Pattern complete.
8. Exit at direction of ring stewards.

Great Lakes Classic

WESTERN RIDING - PATTERN 2

9/16/22

LEGEND

.....	Walk
- - -	Jog
—	Lope
////	Back
▨	Lead Changing Area

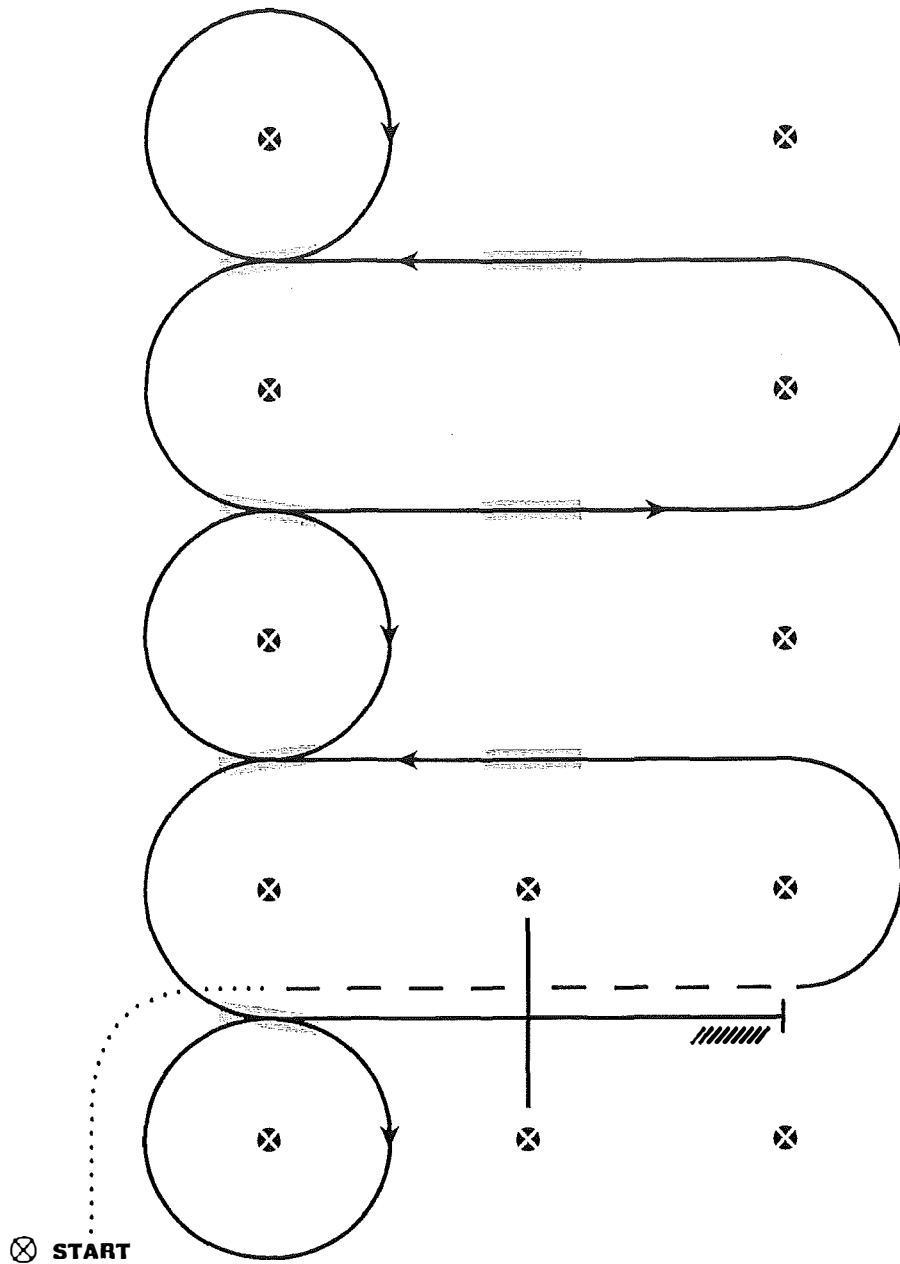

1. Walk at least 15 feet from start cone to the first marker, as drawn, transition to jog, jog over log.
2. Transition to the lope left lead
3. First crossing change
4. Second crossing change
5. Third crossing change
6. Circle & first line change
7. Second line change
8. Third line change
9. Fourth line change & circle
10. Lope over log
11. Lope, stop & back

Great Lakes Classic

LEVEL I WESTERN RIDING PATTERN 2

9/16/22

LEGEND

.....	Walk
- - -	Jog
————	Lope
//////	Back
▨▨▨▨	Lead Changing Area

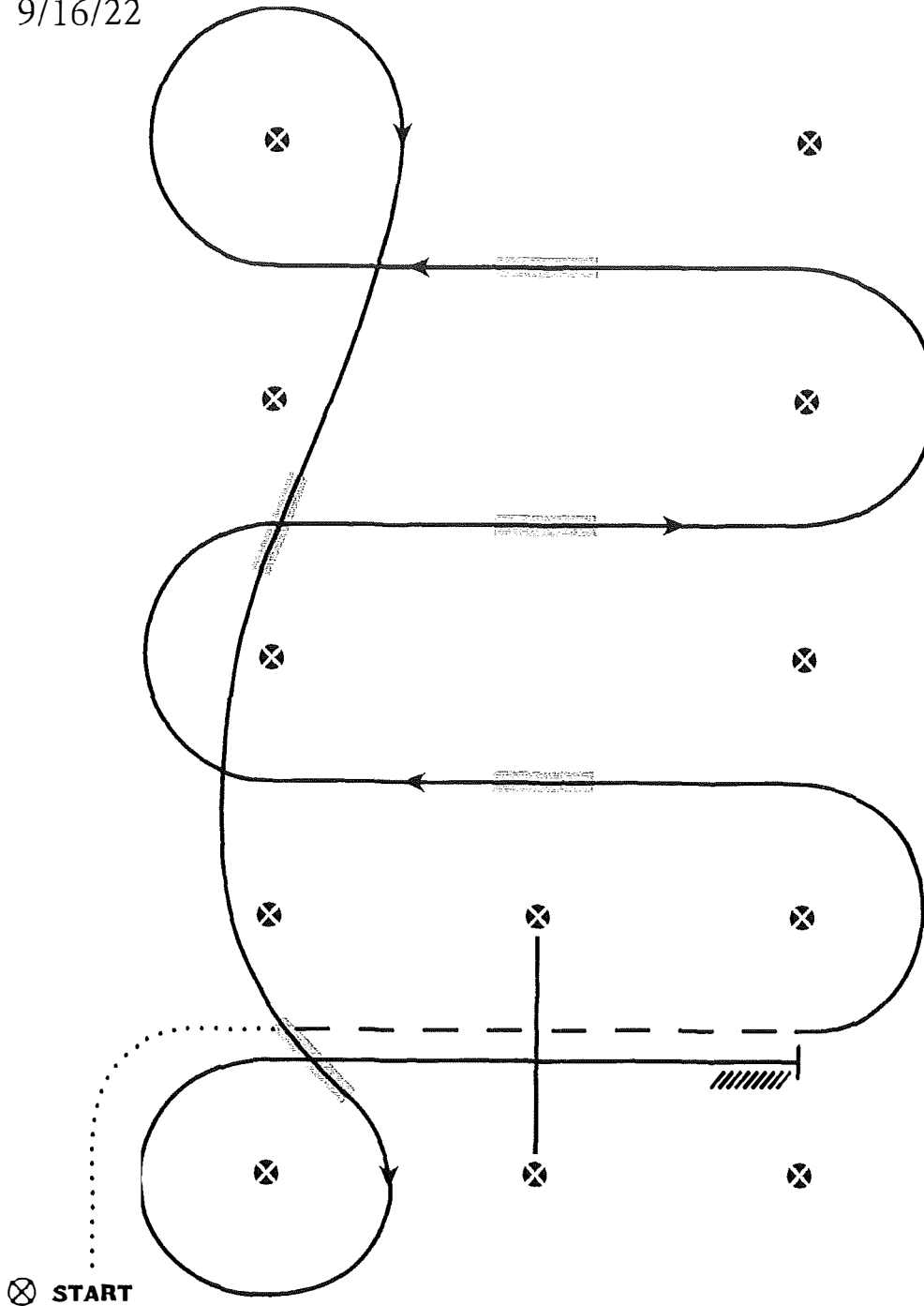

1. Walk at least 15 feet from start cone to the first marker, as drawn, transition to jog, jog over log.
2. Transition to the lope left lead
3. First crossing change
4. Second crossing change
5. Third crossing change
6. Circle & first line change
7. Second line change & circle
8. Lope over log
9. Stop & back

Great Lakes Classic

RANCH RIDING - PATTERN 4

9/16/22

LEGEND

.....	Walk
.....	Extended Walk
- - -	Trot
- - -	Extended Trot
— — —	Lope
— — —	Extended Lope
//////	Back
//	Lead Change

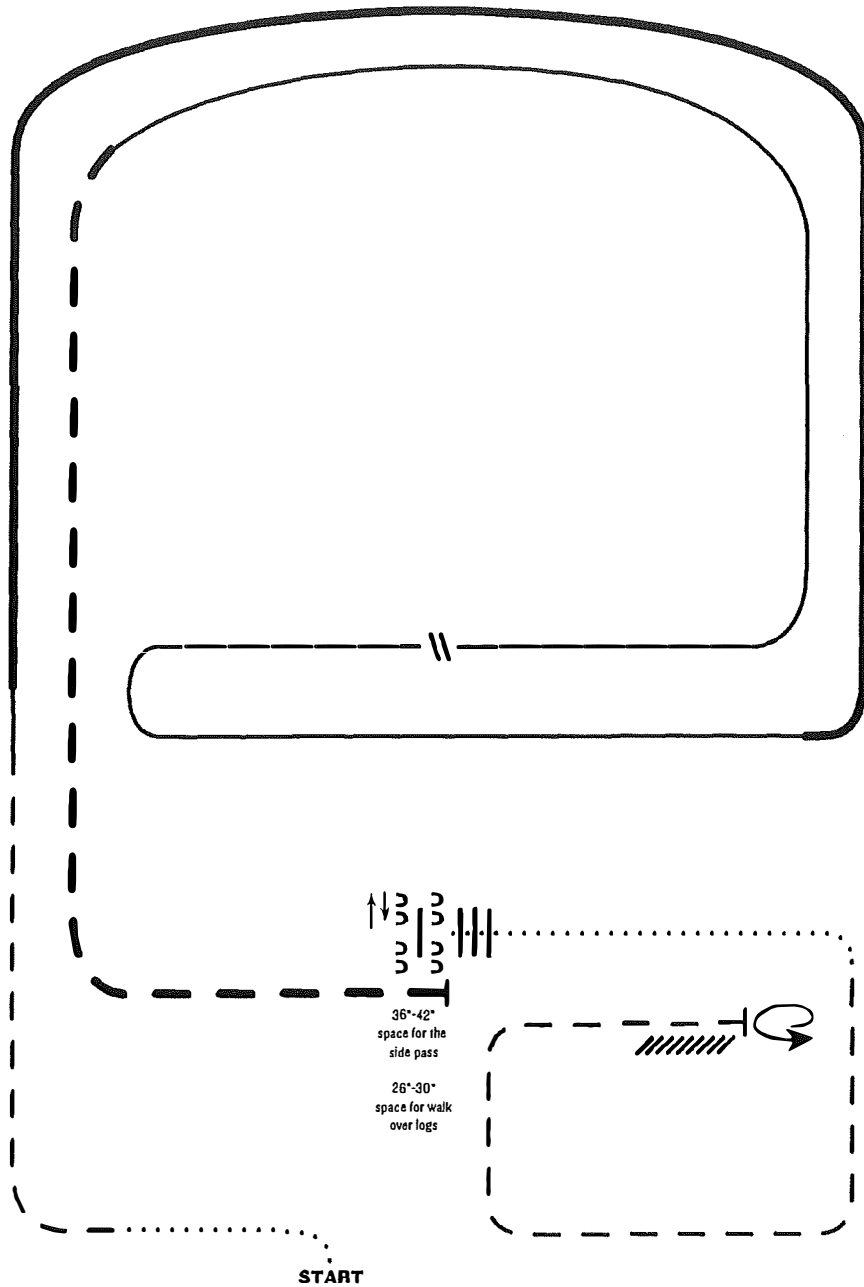

1. Walk
2. Trot
3. Extended lope right lead
4. Lope right lead
5. Change leads (simple or flying)
6. Lope left lead
7. Extended trot
8. Stop, side pass left, side pass right, 1/2 way
9. Walk over logs
10. Walk
11. Trot square
12. Stop, 360° turn left, and back

Note: The drawn description of this pattern is only intended for the general depiction of the pattern. Exhibitors should utilize the arena space to best exhibit their horses.

Revised 05-2021

Great Lakes Classic
Equitation- All Division except
Small Fry
9-17-22

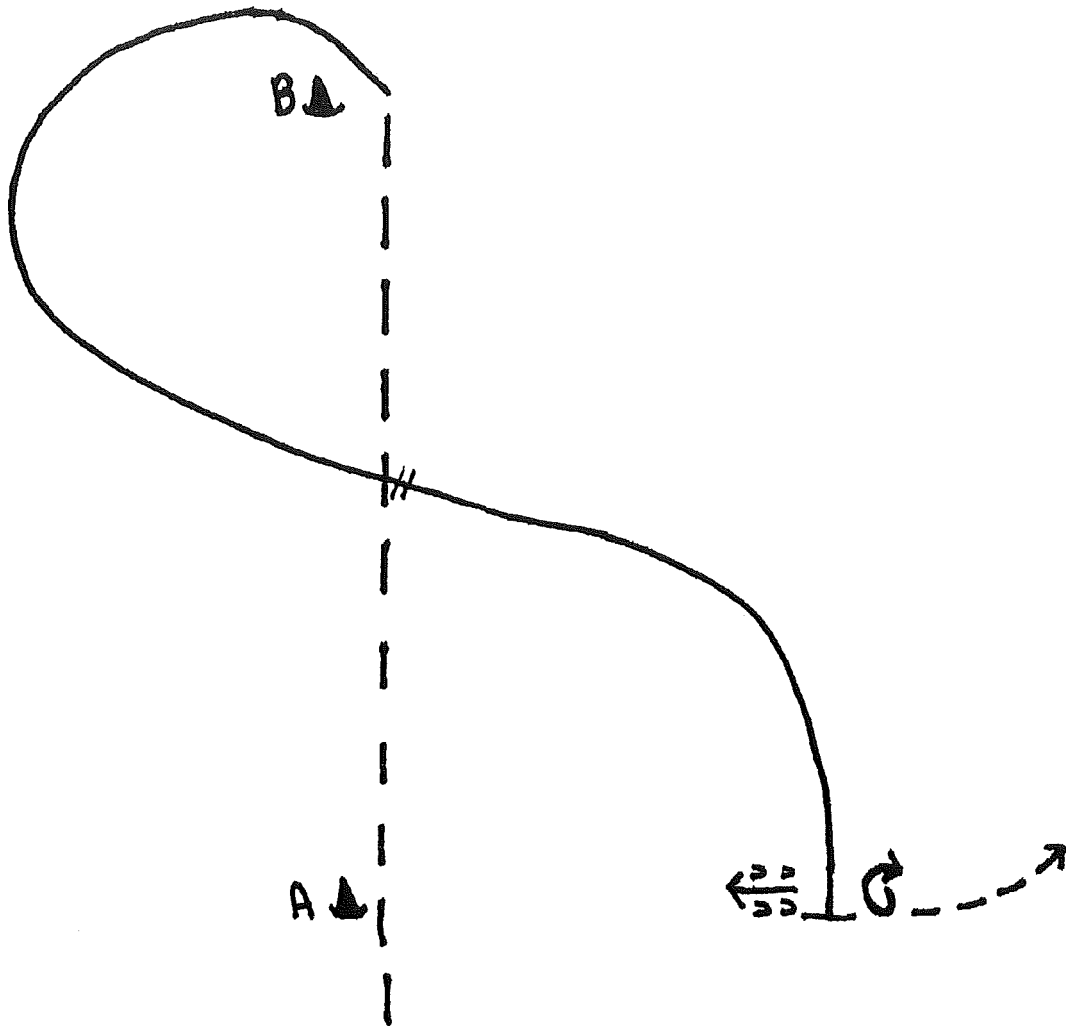

1. Start before A at a sitting trot for 6 steps.
2. Posting trot right diagonal 1/2 way to B.
3. Posting trot left diagonal to B.
4. Canter left lead to center as shown.
5. Change leads (simple or flying)
6. Canter right lead until even with A.
7. Stop and perform a 270 degree forehand turn to the right.
8. Back 1 horse length.
9. Exit at a sitting trot.

Great Lakes Classic

WESTERN RIDING - PATTERN I

9/17/22

LEGEND

.....	Walk
- - -	Jog
————	Lope
///////	Back
	Load Changing Area

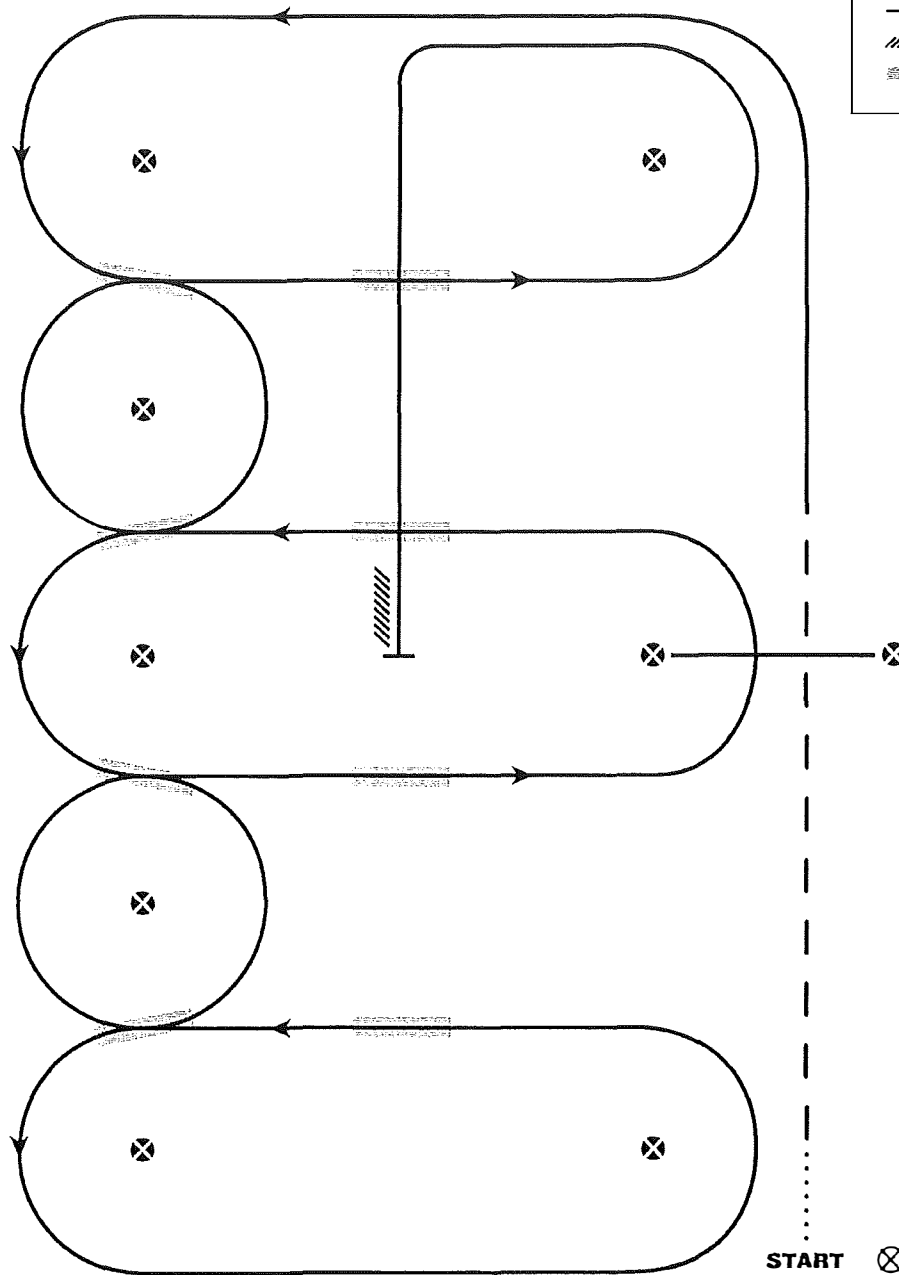

1. Walk at least 15 feet from start cone to the first marker, transition to jog, jog over log
2. Transition to the lope left lead & lope around end
3. First line change
4. Second line change
5. Third line change
6. Fourth line change lope around the end of arena
7. First crossing change
8. Second crossing change
9. Lope over log
10. Third crossing change
11. Fourth crossing change
12. Lope up the center, stop & back

Great Lakes Classic

LEVEL I WESTERN RIDING PATTERN I

9/17/22

LEGEND

.....	Walk
- - - -	Jog
————	Lope
///////	Back
▨▨▨▨▨	Lead Changing Area

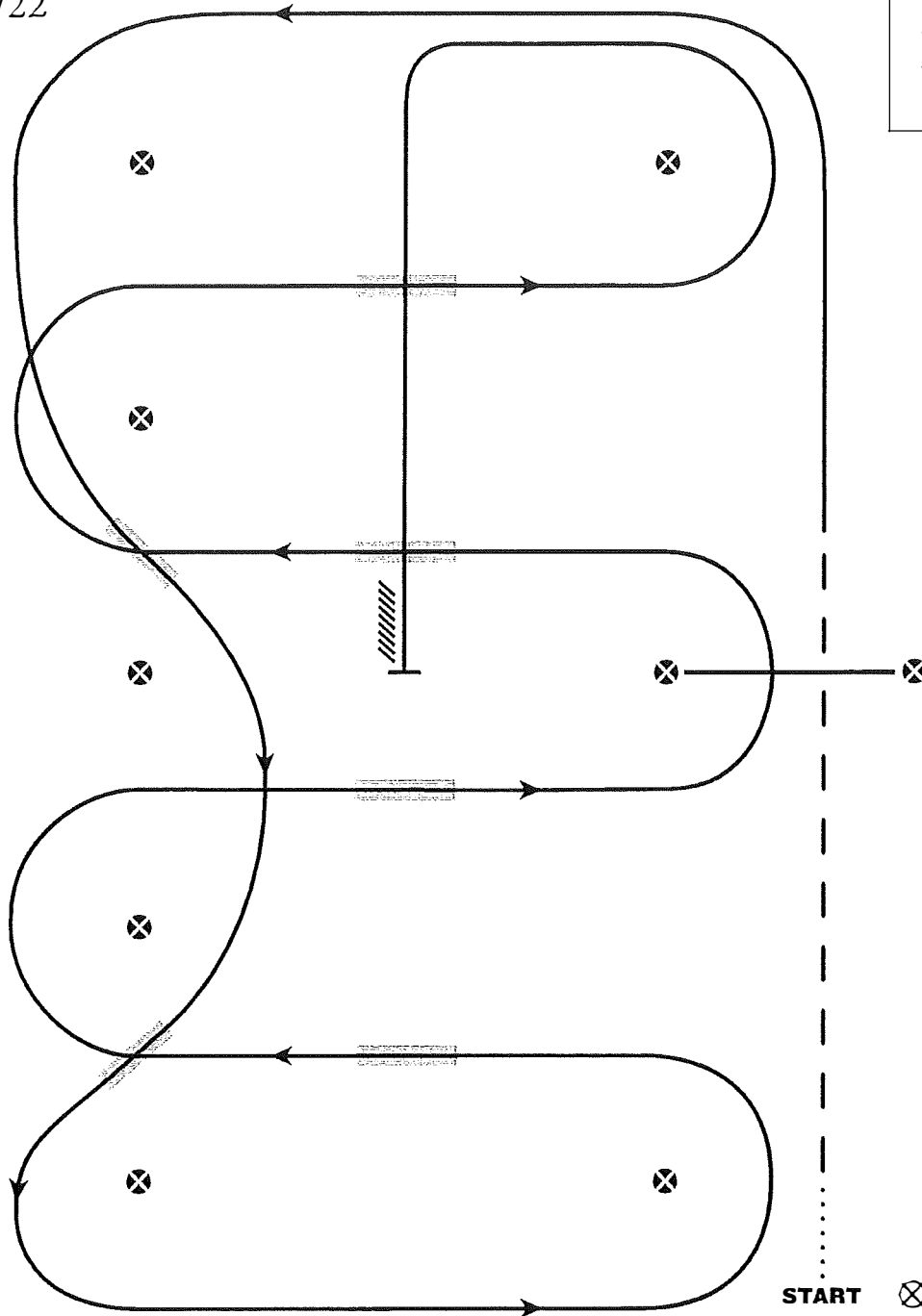

1. Walk at least 15 feet from start cone to the first marker, transition to jog, jog over log.
2. Transition to the lope left lead & lope around end
3. First line change
4. Second line change lope around the end of arena
5. First crossing change
6. Second crossing change
7. Lope over log
8. Third crossing change
9. Fourth crossing change
10. Lope up the center, stop & back

Great Lakes Classic

Showmanship - All Divisions except Small Fry

Show Date: 9/18/22

w w w . H o r s e S h o w P a t t e r n s . c o m

w w w . H o r s e S h o w P a t t e r n s . c o m

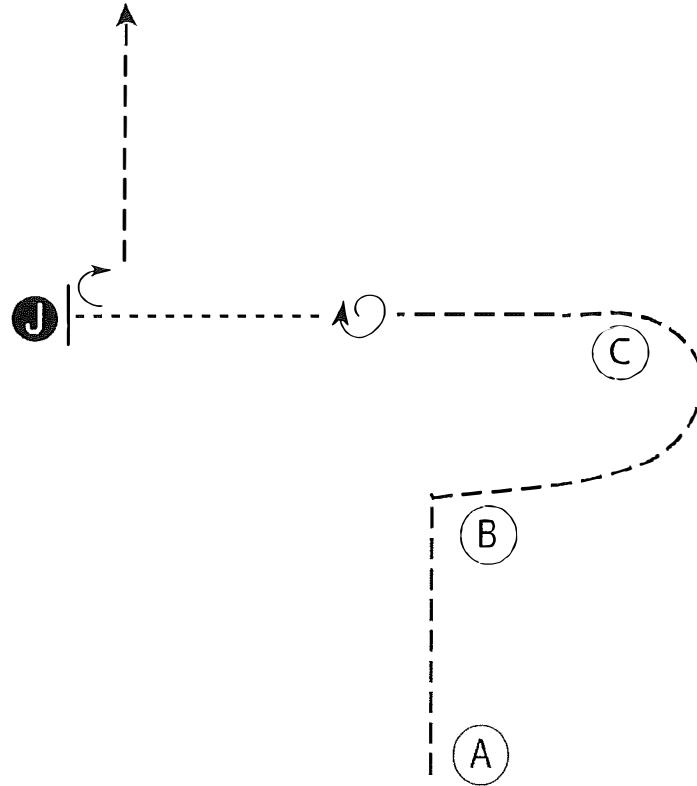

Be ready at A.

1. Trot around B and C as shown.
2. Halfway between C and the judge, stop and do a 360 degree turn.
3. Walk to judge and set up for inspection.
4. When dismissed, do a 90 degree turn and trot away.

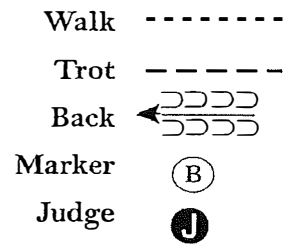

[S/3-21]

Pattern Provided by:

Great Lakes Classic
Horsemanship - All Division
except Small Fry
9-18-22

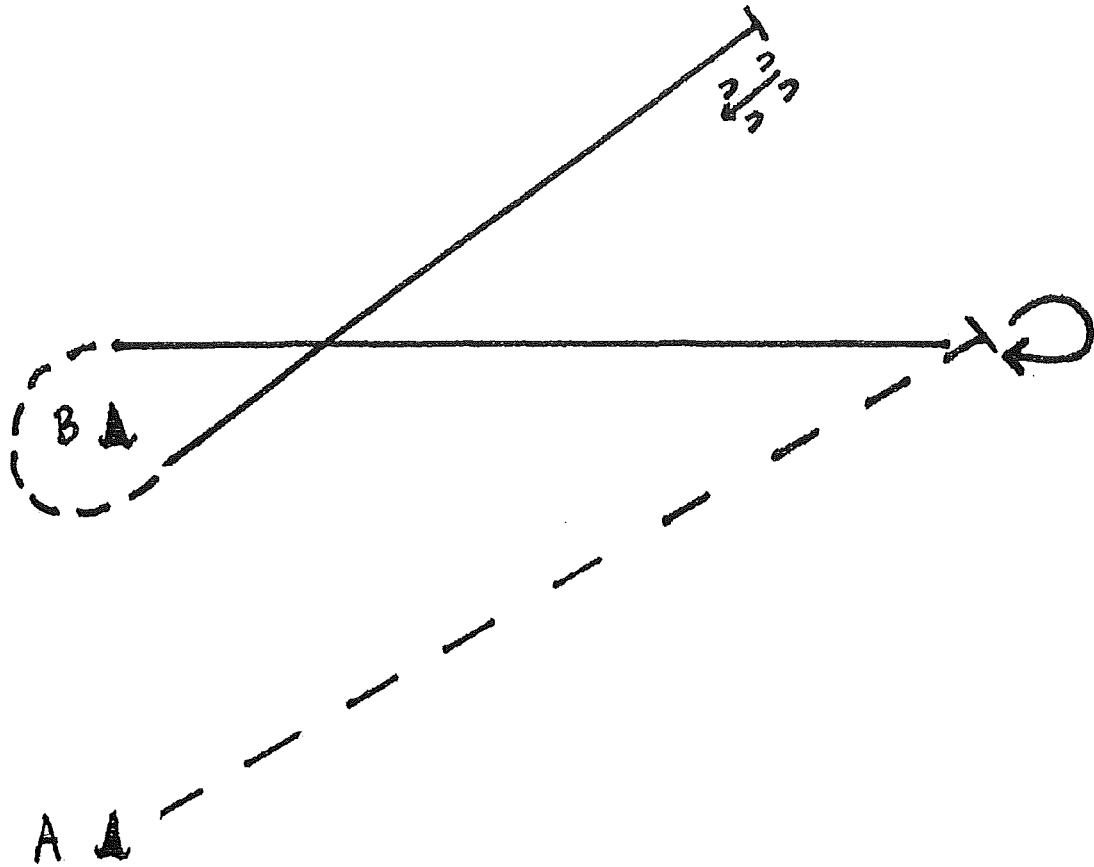

1. Begin at A.
2. Extended trot as shown.
3. Stop and perform an approximate 260 degree turn to the right on the haunches.
4. Lope left lead until even with B.
5. Jog around B.
6. Lope right lead as shown.
7. Stop and back 1 horse length. Pattern complete
8. Exit at direction of ring stewards.

Great Lakes Classic

RANCH RIDING - PATTERN 10

9/18/22

OPTIONAL
CATTLE

LEGEND	
.....	Walk
.....	Extended Walk
- - - -	Trot
- - - -	Extended Trot
————	Lope
————	Extended Lope
//////	Back
	Lead Change

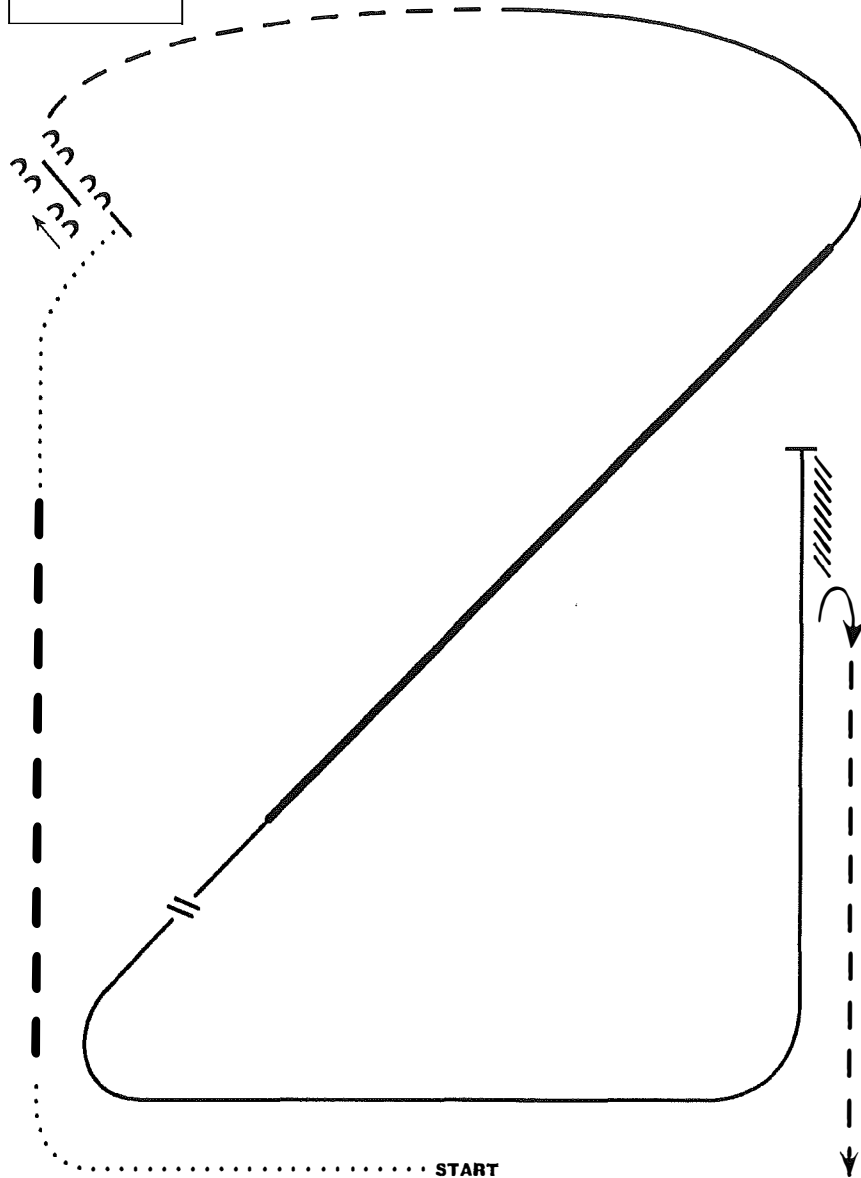

1. Walk
2. Extended trot
3. Walk
4. Stop, side pass left over log
5. Trot
6. Lope right lead
7. Extended lope right lead
8. Collect lope and change leads (simple or flying)
9. Lope left lead
10. Stop and back
11. 1/2 turn right
12. Trot

Note: The drawn description of this pattern is only intended for the general depiction of the pattern. Exhibitors should utilize the arena space to best exhibit their horses.